

i3 Ventless Submittal Information

Spec Sheet	1.1
UL Ventless Label	2.1
Notice of Authorization to Apply to UL Mark	3.1
UL Listing	4.1
UL KNLZ Explained	5.1
Emissions Test Results	6.1
Emissions by Product.....	7.1
Fire and Smoke Statement.....	8.1
Energy Usage Estimate.....	9.1
Surface Temperatures.....	10.1
County of Los Angeles Public Health Approval	11.1
TurboChef Installation Recommendations	12.1



Project _____

Item No. _____

Quantity _____

i3™

THE i3™



PERFORMANCE

Utilizing TurboChef's patented technology to rapidly cook food without compromising quality, the i3 oven provides superior cooking performance while requiring less space and consuming less energy.

VENTILATION

- UL (KNLZ) listed for ventless operation.†
- EPA 202 test (8 hr):
 - Product: Pepperoni Pizzas
 - Results: 0.32 mg/m³
 - Ventless Requirement: <5.00 mg/m³
- Internal catalytic filtration to limit smoke, grease, and odor emissions.

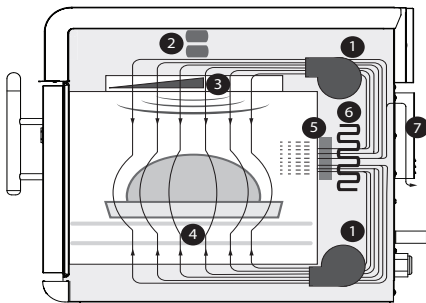

1. Blower Motors
2. Microwave System
3. Stirred Impinged Air (Top) and Microwave
4. Impinged Air (Bottom)
5. Catalytic Converter
6. Impingement Heater
7. Vent Tube Catalyst

EXTERIOR CONSTRUCTION

- Two-tone stainless steel front, top and sides
- 304 stainless steel removable grease collection pan
- Ergonomic door handle
- Rubber seal for surface mounting
- Side hand grips for lifting

INTERIOR CONSTRUCTION

- 304 stainless steel
- Fully insulated cook chamber
- Removable rack
- Top and bottom jetplates

STANDARD FEATURES

- Integral recirculating catalytic converter for UL (KNLZ) listed ventless operation
- Independently-controlled dual motors for vertically-recirculated air impingement
- Top-launched microwave system
- Stirrer to help ensure even distribution of air and microwave
- External air filtration
- Smart menu system capable of storing up to 200 recipes
- Flash software updates via smart card
- Single or multiple-temperature interface
- Smart Voltage Sensor Technology* (U.S. only)
- Vent catalyst to further limit emissions
- Built-in self-diagnostics for monitoring oven components and performance
- Stackable (requires stacking stand)
- Field-configurable for single or 3-phase operation
- Includes plug and cord (6 ft. nominal)
- Warranty – 1 year parts and labor

COMES WITH STANDARD ACCESSORIES

- 1 Aluminum Paddle (NGC-1478)
- 1 Bottle Oven Cleaner (103180)
- 1 Bottle Oven Guard (103181)
- 2 Trigger Sprayers (103182)
- 2 PTFE Baskets (NGC-1331)



This product conforms to the ventilation recommendations set forth by NFPA96 using EPA202 test method.

* Smart Voltage Sensor Technology does not compensate for lack of or over voltage situations. It is the responsibility of the owner to supply voltage to the unit according to the specifications on the back of this sheet.

† Ventless certification is for all food items except for foods classified as "fatty raw proteins." Such foods include bone-in, skin-on chicken, raw hamburger meat, raw bacon, raw sausage, steaks, etc. If cooking these types of foods, consult local HVAC codes and authorities to ensure compliance with ventilation requirements.

Ultimate ventless allowance is dependent upon AHJ approval, as some jurisdictions may not recognize the UL certification or application. If you have questions regarding ventless certifications or local codes please email ventless.help@turbochef.com

TurboChef reserves the right to make substitutions of components or change specifications without prior notice.

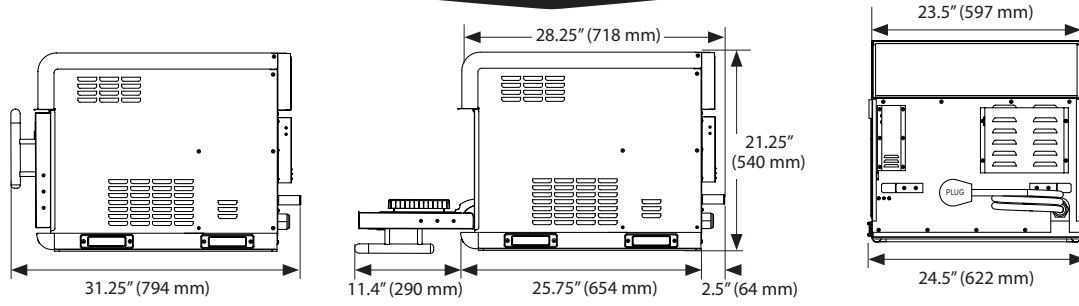

DIMENSIONS		
Single Units		
Height	21.25"	540 mm
Width	24.5"	622 mm
Depth	31.25"	794 mm
Weight	245 lb.	111 kg
Cook Chamber		
Height	6.9"	175 mm
Width	19.4"	493 mm
Depth (Door Open / Closed)	14.75" / 12.75"	375 mm / 324 mm
Volume	1.14 cu.ft.	32.3 liters
Wall Clearance (Oven not intended for built-in installation)		
Top	19"	483 mm
Sides	2"	51 mm
ELECTRICAL SPECIFICATIONS-SINGLE PHASE		
i3 US Model (i3-9500-1) - United States		
Voltage	208/240 VAC	
Frequency	60 Hz	
Current (Max Circuit Requirement)	40 amp (40 amp)	
Max Input	8300/9600 watts	
i3 UK Model (i3-9500-2-U) - United Kingdom		
Voltage	230 VAC	
Frequency	50 Hz	
Current (Max Circuit Requirement)	40 amp (62 amp)	
Max Input	9200 watts	
i3 BK Model (i3-9500-6-BK) - Brazil		
Voltage	220 VAC	
Frequency	60 Hz	
Current (Max Circuit Requirement)	40 amp (50 amp)	
Max Input	8800 watts	
i3 LA Model (i3-9500-7-LA) - Latin America		
Voltage	220 VAC	
Frequency	60 Hz	
Current (Max Circuit Requirement)	40 amp (50 amp)	
Max Input	8800 watts	
i3 JK Model - 50 Hz (i3-9500-8-JK) - Japan 60 Hz (i3-9500-10-JK) - Japan		
Voltage	200 VAC	
Frequency	50 Hz or 60 Hz	
Current (Max Circuit Requirement)	40 amp (40 amp)	
Max Input	8000 watts	
ELECTRICAL SPECIFICATIONS-MULTI PHASE		
i3 DL Model (i3-9500-14-DL) - United States		
Voltage	208/240 VAC	
Frequency	60 Hz	
Current (Max Circuit Requirement)	24 amp (30 amp)	
Max Input	8600/9900 watts	

i3 ED Model (i3-9500-3-ED) - International		
Voltage	230 VAC	
Frequency	50 Hz	
Current (Max Circuit Requirement)	24 amp (32 amp)	
Max Input	9500 watts	
i3 EW Model (i3-9500-4-EW) - International		
Voltage	400 VAC	
Frequency	50 Hz	
Current (Max Circuit Requirement)	14 amp (20 amp)	
Max Input	9500 watts	
i3 AU Model (i3-9500-5-AU) - Australia		
Voltage	400 VAC	
Frequency	50 Hz	
Current (Max Circuit Requirement)	14 amp (20 amp)	
Max Input	9500 watts	
i3 JD Model - 50 Hz (i3-9500-9-JD) - Japan 60 Hz (i3-9500-11-JD) - Japan		
Voltage	200 VAC	
Frequency	50 Hz or 60 Hz	
Current (Max Circuit Requirement)	23 amp (30 amp)	
Max Input	8000 watts	
i3 KW Model (i3-9500-12-KW) - Middle East & Korea		
Voltage	400 VAC	
Frequency	60 Hz	
Current (Max Circuit Requirement)	14 amp (20 amp)	
Max Input	9500 watts	
i3 SD Model (i3-9500-13-SD) - Middle East & Korea		
Voltage	230 VAC	
Frequency	60 Hz	
Current (Max Circuit Requirement)	24 amp (30 amp)	
Max Input	9200 watts	
i3 LD Model (i3-9500-15-LD) - Latin America		
Voltage	220 VAC	
Frequency	60 Hz	
Current (Max Circuit Requirement)	24 amp (30 amp)	
Max Input	9100 watts	
i3 BD Model (i3-9500-16-BD) - Brazil		
Voltage	220 VAC	
Frequency	60 Hz	
Current (Max Circuit Requirement)	24 amp (30 amp)	
Max Input	9100 watts	
SHIPPING INFORMATION		
U.S.: All ovens shipped within the U.S. are packaged in a double-wall corrugated box banded to a wooden skid. International: All International ovens shipped via Air or Less than Container Loads are packaged in wooden crates.		
Box size: 34" (L) x 30" (W) x 32" (H) / 864 mm x 762 mm x 813 mm Crate size: 37" (L) x 33" (W) x 34" (H) / 940 mm x 838 mm x 864 mm Item class: 110 NMFC #26710 HS code 8419.81		
Boxed weight: 290 lb. (132 kg) Crated weight: 365 lb. (166 kg)		
Minimum entry clearance required for box: 30.5" (775 mm) Minimum entry clearance required for crate: 33.5" (851 mm)		

TurboChef recommends installing a type D circuit breaker for European installations.
TurboChef reserves the right to substitute components or change specifications without notice.
© 2009-2017 TurboChef Technologies, Inc.



THE i3 Touch™



i3 Touch™

Project _____

Item No. _____

Quantity _____

PERFORMANCE

Utilizing TurboChef's patented technology to rapidly cook food without compromising quality, the i3 Touch oven provides superior cooking performance while requiring less space and consuming less energy.

VENTILATION

- UL (KNLZ) listed for ventless operation.[†]
- EPA 202 test (8 hr):
 - Product: Pepperoni Pizzas
 - Results: 0.32 mg/m³
 - Ventless Requirement: <5.00 mg/m³
- Internal catalytic filtration to limit smoke, grease, and odor emissions.

EXTERIOR CONSTRUCTION

- Two-tone stainless steel front, top and sides
- 304 stainless steel removable grease collection pan
- Ergonomic door handle
- Rubber seal for surface mounting
- Side hand grips for lifting
- 7-inch capacitive touch screen with tempered glass cover

INTERIOR CONSTRUCTION

- 304 stainless steel
- Fully insulated cook chamber
- Removable rack
- Top and bottom jetplates

STANDARD FEATURES

- Simple and intuitive touch controls
- Integral recirculating catalytic converter for UL (KNLZ) listed ventless operation
- Independently-controlled dual motors for vertically-recirculated air impingement
- Top-launched microwave system
- Stirrer to help ensure even distribution of air and microwave
- External air filtration
- Smart menu system capable of storing up to 200 recipes
- Flash firmware updates via USB
- Programmable via USB
- Single or multiple-temperature interface
- Smart Voltage Sensor Technology* (U.S. only)
- Vent catalyst to further limit emissions
- Self-diagnostics for monitoring oven components and performance
- Stackable (requires stacking stand)
- Field-configurable for single or 3-phase operation
- Includes plug and cord (6 ft. nominal)
- Warranty – 1 year parts and labor

COMES WITH STANDARD ACCESSORIES

- 1 Aluminum Paddle (NGC-1478)
- 1 Bottle Oven Cleaner (103180)
- 1 Bottle Oven Guard (103181)
- 2 Trigger Sprayers (103182)
- 2 PTFE Baskets (NGC-1331)

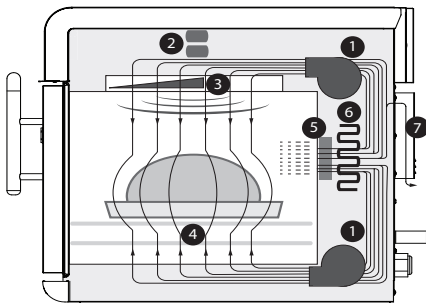

1. Blower Motors
2. Microwave System
3. Stirred Impinged Air (Top) and Microwave
4. Impinged Air (Bottom)
5. Catalytic Converter
6. Impingement Heater
7. Vent Tube Catalyst



This product conforms to the ventilation recommendations set forth by NFPA96 using EPA202 test method.

* Smart Voltage Sensor Technology does not compensate for lack of or over voltage situations. It is the responsibility of the owner to supply voltage to the unit according to the specifications on the back of this sheet.

[†] Ventless certification is for all food items except for foods classified as "fatty raw proteins." Such foods include bone-in, skin-on chicken, raw hamburger meat, raw bacon, raw sausage, steaks, etc. If cooking these types of foods, consult local HVAC codes and authorities to ensure compliance with ventilation requirements.

Ultimate ventless allowance is dependent upon AHJ approval, as some jurisdictions may not recognize the UL certification or application. If you have questions regarding ventless certifications or local codes please email ventless.help@turbochef.com

TurboChef reserves the right to make substitutions of components or change specifications without prior notice.

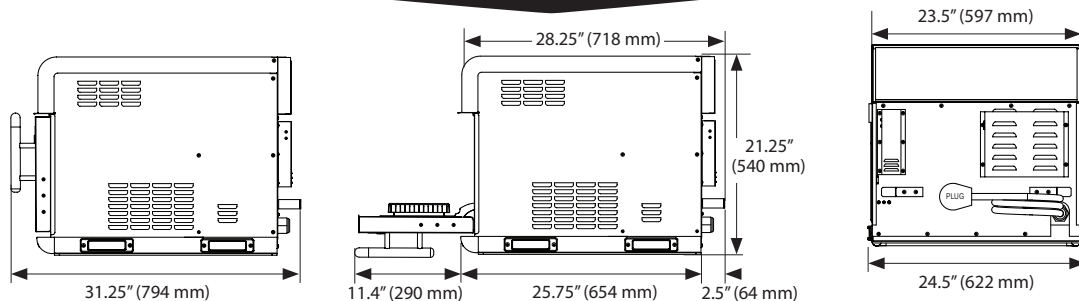

DIMENSIONS		
Single Units		
Height	21.25"	540 mm
Width	24.5"	622 mm
Depth	31.25"	794 mm
Weight	245 lb.	111 kg
Cook Chamber		
Height	6.9"	175 mm
Width	19.4"	493 mm
Depth (Door Open / Closed)	14.75" / 12.75"	375 mm / 324 mm
Volume	1.14 cu.ft.	32.3 liters
Wall Clearance (Oven not intended for built-in installation)		
Top	19"	483 mm
Sides	2"	51 mm
ELECTRICAL SPECIFICATIONS-SINGLE PHASE		
i3 US Model (i3-9500-401) - United States		
Voltage	208/240 VAC	
Frequency	60 Hz	
Current (Max Circuit Requirement)	40 amp (40 amp)	
Max Input	8300/9600 watts	
i3 UK Model (i3-9500-402-UK) - United Kingdom		
Voltage	230 VAC	
Frequency	50 Hz	
Current (Max Circuit Requirement)	40 amp (62 amp)	
Max Input	9200 watts	
i3 BK Model (i3-9500-406-BK) - Brazil		
Voltage	220 VAC	
Frequency	60 Hz	
Current (Max Circuit Requirement)	40 amp (50 amp)	
Max Input	8800 watts	
i3 LA Model (i3-9500-407-LA) - Latin America		
Voltage	220 VAC	
Frequency	60 Hz	
Current (Max Circuit Requirement)	40 amp (50 amp)	
Max Input	8800 watts	
i3 JK Model - 50 Hz (i3-9500-408-JK) - Japan 60 Hz (i3-9500-410-JK) - Japan		
Voltage	200 VAC	
Frequency	50 Hz or 60 Hz	
Current (Max Circuit Requirement)	40 amp (40 amp)	
Max Input	8000 watts	
ELECTRICAL SPECIFICATIONS-MULTI PHASE		
i3 DL Model (i3-9500-414-DL) - United States		
Voltage	208/240 VAC	
Frequency	60 Hz	
Current (Max Circuit Requirement)	24 amp (30 amp)	
Max Input	8600/9900 watts	

i3 ED Model (i3-9500-403-ED) - International		
Voltage	230 VAC	
Frequency	50 Hz	
Current (Max Circuit Requirement)	24 amp (32 amp)	
Max Input	9500 watts	
i3 EW Model (i3-9500-404-EW) - International		
Voltage	400 VAC	
Frequency	50 Hz	
Current (Max Circuit Requirement)	14 amp (20 amp)	
Max Input	9500 watts	
i3 AU Model (i3-9500-405-AU) - Australia		
Voltage	400 VAC	
Frequency	50 Hz	
Current (Max Circuit Requirement)	14 amp (20 amp)	
Max Input	9500 watts	
i3 JD Model - 50 Hz (i3-9500-409-JD) - Japan 60 Hz (i3-9500-411-JD) - Japan		
Voltage	200 VAC	
Frequency	50 Hz or 60 Hz	
Current (Max Circuit Requirement)	23 amp (30 amp)	
Max Input	8000 watts	
i3 KW Model (i3-9500-412-KW) - Middle East & Korea		
Voltage	400 VAC	
Frequency	60 Hz	
Current (Max Circuit Requirement)	14 amp (20 amp)	
Max Input	9500 watts	
i3 SD Model (i3-9500-413-SD) - Middle East & Korea		
Voltage	230 VAC	
Frequency	60 Hz	
Current (Max Circuit Requirement)	24 amp (30 amp)	
Max Input	9200 watts	
i3 LD Model (i3-9500-415-LD) - Latin America		
Voltage	220 VAC	
Frequency	60 Hz	
Current (Max Circuit Requirement)	24 amp (30 amp)	
Max Input	9100 watts	
i3 BD Model (i3-9500-416-BD) - Brazil		
Voltage	220 VAC	
Frequency	60 Hz	
Current (Max Circuit Requirement)	24 amp (30 amp)	
Max Input	9100 watts	
SHIPPING INFORMATION		
U.S.: All ovens shipped within the U.S. are packaged in a double-wall corrugated box banded to a wooden skid. International: All International ovens shipped via Air or Less than Container Loads are packaged in wooden crates.		
Box size: 34" (L) x 30" (W) x 32" (H) / 864 mm x 762 mm x 813 mm Crate size: 37" (L) x 33" (W) x 34" (H) / 940 mm x 838 mm x 864 mm Item class: 110 NMFC #26710 HS code 8419.81		
Boxed weight: 290 lb. (132 kg) Crated weight: 365 lb. (166 kg)		
Minimum entry clearance required for box: 30.5" (775 mm) Minimum entry clearance required for crate: 33.5" (851 mm)		

TurboChef recommends installing a type D circuit breaker for European installations.
 TurboChef reserves the right to substitute components or change specifications without notice.
 © 2015-2017 TurboChef Technologies, Inc.



81Y5

LISTED

Commercial Cooking Appliance
with Integral Systems for Limiting
the Emissions of Grease-Laden Air

This Product Conforms to the Ventilation Recommendations
Set Forth by NFPA96 Using EPA202 Test Method



the standard in safety

Underwriters
Laboratories

NOTICE OF AUTHORIZATION TO APPLY THE UL MARK

05/08/2009

Turbochef Technologies Inc
Mr. David Castillo
Suite 105
4240 International Pky
Carrollton Tx 75007, Us

Our Reference:	File E151487, Vol. 1	Project Number	09NK02476
Your Reference:	i3-David Castillo 1/13/09		
Project Scope:	NEW COMPLEMENTARY LISTING OF TURBOCHEF'S MODEL i3 MICROWAVE/CONVECTION OVEN TO KNLZ/KNLZ7		

Dear Mr. David Castillo:

UL's investigation of your product(s) has been completed under the above Reference Number and the product was determined to comply with the applicable requirements.

This letter temporarily supplements the UL Follow-Up Services Procedure and serves as authorization to apply the UL Mark only at authorized factories under UL's Follow-Up Service Program.

To provide the manufacturer with the intended authorization to use the UL Mark, the addressee must send a copy of this notice to each manufacturing location currently authorized in File E151487, Vol. 1.

This authorization is effective from the date of this Notice and only for products at the indicated manufacturing locations. Records in the Follow-Up Services Procedure covering the product are now being prepared and will be sent in the near future. This letter authorizes application of the UL Mark for 90 days from the date of this letter.

Products that bear the UL Mark shall be identical to those that were evaluated by UL and found to comply with UL's requirements. If changes in construction are discovered, appropriate action will be taken for products not in conformance with UL's requirements and continued use of the UL Mark may be withdrawn. UL may elect to withdraw use of the UL Mark if the Applicant or Manufacturer fails to comply with UL's requirements including ongoing compliance of the product, under UL's Follow-Up Service.



Notice of Authorization - 09NK02476

Any information and documentation provided to you involving UL Mark services are provided on behalf of Underwriters Laboratories Inc. (UL) or any authorized licensee of UL.

The contents of this Letter are intended solely for the use of UL and the Applicant. The opinions and findings of UL represent its judgment given with due consideration to the necessary limitations of practical operation in accordance with UL's objectives and purposes. UL shall not otherwise be responsible for the use of or reliance upon the contents of this letter by anyone. UL shall not incur any obligation or liability for any loss, expense or damages, including incidental, consequential or punitive damages, arising out of or in connection with the use or reliance upon the contents of this letter to anyone other than the Applicant as provided in the agreement between UL and Applicant. Any use or reference to UL's name or certification mark(s) by anyone other than the Applicant in accordance with the agreement is prohibited without the express written approval of UL.

Very truly yours,

William Morler

Project Engineer
William.Morler@us.ul.com

Reviewed by:

Fred Zaplatosch
847-664-2853
Staff Engineer
Fred.Zaplatosch@us.ul.com

NBK62B9-14F506

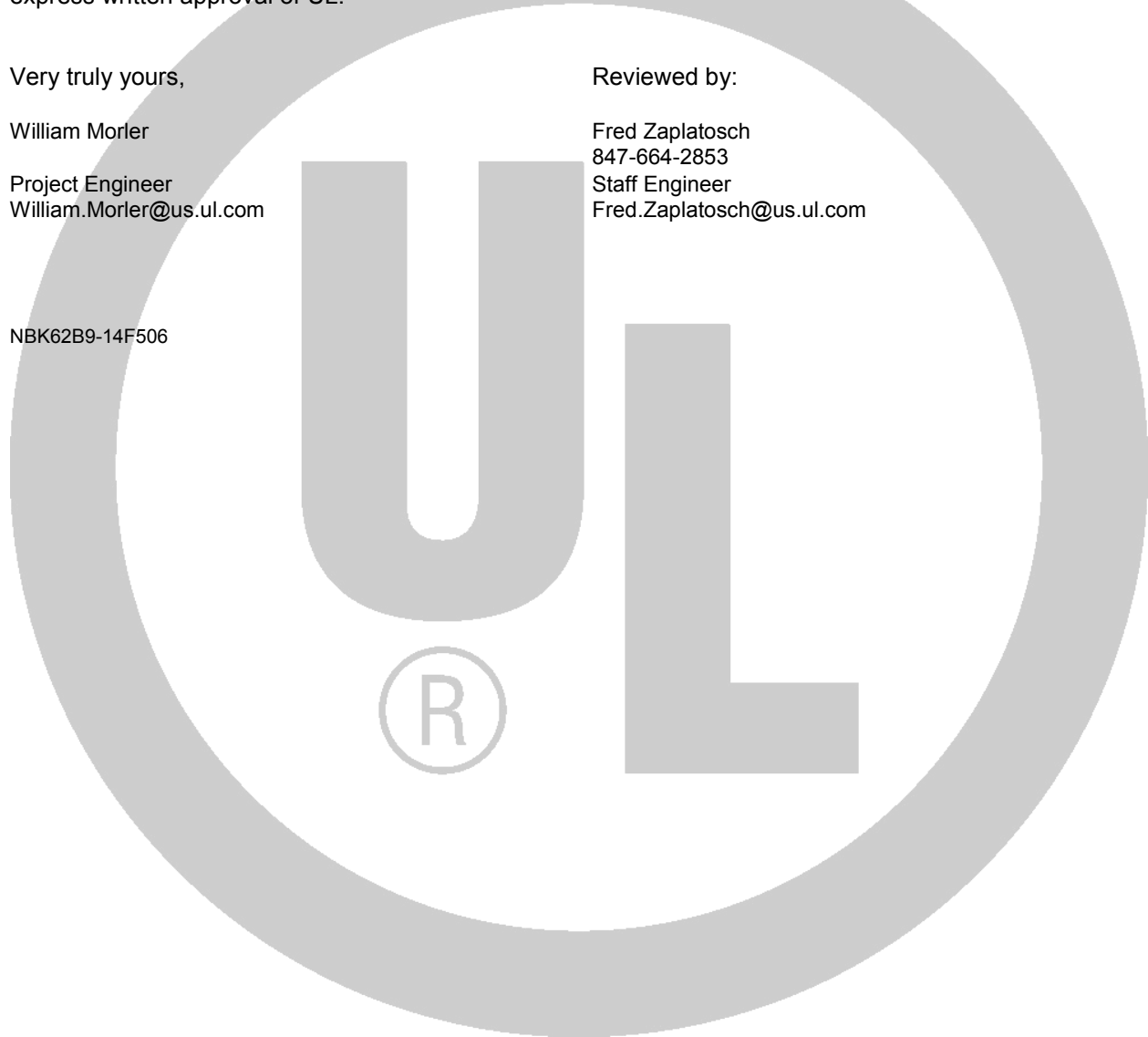

KNLZ.E151487 - COMMERCIAL COOKING APPLIANCES WITH INTEGRAL SYSTEMS FOR LIMITING THE EMISSION OF GREASE-LADEN AIR

Commercial Cooking Appliances with Integral Systems for Limiting the Emission of Grease-laden Air

See General Information for Commercial Cooking Appliances with Integral Systems for Limiting the Emission of Grease-laden Air

TURBOCHEF TECHNOLOGIES INC

E151487

2801 Trade Center Drive
Carrollton, TX 75007 USA

Commercial microwave/convection ovens, Model(s) *C3/C*, Encore 2, Encore*, i3*, i5*, NGC*, NGO*, Eco*

Commercial ovens, Model(s) *HHB, HHB2, HHD*

Conveyor Ovens, Model(s) *HCW2620, HHC1618, HHC2020*

* - Indicated complementary listed models.

Trademark and/or Tradename: "BULLET"

Last Updated on 2018-06-07

The appearance of a company's name or product in this database does not in itself assure that products so identified have been manufactured under UL's Follow-Up Service. Only those products bearing the UL Mark should be considered to be Certified and covered under UL's Follow-Up Service. Always look for the Mark on the product.

UL permits the reproduction of the material contained in the Online Certification Directory subject to the following conditions: 1. The Guide Information, Assemblies, Constructions, Designs, Systems, and/or Certifications (files) must be presented in their entirety and in a non-misleading manner, without any manipulation of the data (or drawings). 2. The statement "Reprinted from the Online Certifications Directory with permission from UL" must appear adjacent to the extracted material. In addition, the reprinted material must include a copyright notice in the following format: "© 2018 UL LLC".

UL and the UL logo are trademarks of UL LLC ©2018 All Rights Reserved.

[About](#) [Privacy Policy](#) [Terms & Conditions](#) [Access Your Data](#)

KNLZ.GuideInfo - COMMERCIAL COOKING APPLIANCES WITH INTEGRAL SYSTEMS FOR LIMITING THE EMISSION OF GREASE-LADEN AIR

[Heaters and Heating Equipment] (Heaters, Cooking Appliances) Commercial Cooking Appliances with Integral Systems for Limiting the Emission of Grease-laden Air

See General Information for Heaters, Cooking Appliances

USE AND INSTALLATION

This category covers cooking equipment intended for commercial use, such as pressurized deep fat fryers and other appliances for use in commercial kitchens, restaurants or other business establishments where food is prepared. Each appliance covered under this category is manufactured with an integral system feature to limit the emission of grease-laden air from the cooking process to the room ambient.

These appliances have been investigated for the limit of 5 mg/m³ for the emission of grease-laden air to the room ambient in accordance with the recommendations of ANSI/NFPA 96, "Ventilation Control and Fire Protection of Commercial Cooking Operations," using the EPA-202 test method prescribed for cooking appliances provided with integral recirculating air systems.

These products are not intended for connection to a ducted exhaust system.

Appliances in this category are not provided with an integral fire extinguishing system. Authorities having jurisdiction should be consulted as to the requirements for this equipment with respect to fire extinguishing systems, such as the need for field installed systems in accordance with ANSI/NFPA 96.

In cases where the nature or construction of equipment is such that special precautions beyond the requirements of ANSI/NFPA 70, "National Electrical Code," must be observed in installations or use, suitable warning or special instructions are marked on the equipment.

Appliances covered under this category are suitable for wiring with either copper or aluminum power-supply conductors unless marked "Use Copper Wire Only For Power Supply Connections."

Commercial cooking appliances of certain types are designed for permanent connections to water supply and sewer lines at the point of installation. Authorities having jurisdiction should be consulted as to the requirements for this equipment with respect to sanitation and connection to water supply and waste disposal lines.

FACTORS NOT INVESTIGATED

Neither the toxicity of coatings nor the physiological effects on persons consuming food products prepared by use of these appliances has been investigated.

PRODUCT IDENTITY

One of the following product identities appears on the product:

Commercial Cooking Appliance with Integral System for Limiting the Emission of Grease-laden Air

Cooking Appliance with Integral System for Limiting the Emission of Grease-laden Air

Other product identities may be used as shown in the individual certifications, followed by the words "with Integral System for Limiting the Emission of Grease-laden Air."

RELATED PRODUCTS

For products with integral recirculating systems including fire extinguishing systems, see Commercial, with Integral Recirculating Systems (KNKG).

For cooking oil filters that are not an integral part of another appliance, see Commercial Filters for Cooking Oil (KNRF).

ADDITIONAL INFORMATION

For additional information, see Electrical Equipment for Use in Ordinary Locations (AALZ) and Heating, Cooling, Ventilating and Cooking Equipment (AAHC).

REQUIREMENTS

The basic standard used to investigate products in this category is ANSI/UL 197, "Commercial Electric Cooking Appliances."

Appliances covered under this category with an integral cooking oil filter have been additionally investigated to ANSI/UL 1889, "Commercial Filters for Cooking Oil."

UL MARK

The Certification Mark of UL on the product is the only method provided by UL to identify products manufactured under its Certification and Follow-Up Service. The Certification Mark for these products includes the UL symbol, the words "CERTIFIED" and "SAFETY," the geographic identifier(s), and a file number.

Alternate UL Mark

The Listing Mark of UL on the product is the only method provided by UL to identify products manufactured under its Listing and Follow-Up Service. The Listing Mark for these products includes the UL symbol (as illustrated in the Introduction of this Directory) together with the word "LISTED," a control number, and the product name "Commercial Cooking Appliance" or "Cooking Appliance," or other appropriate product name as shown in the individual Listings, together with the words "with integral system for limiting the emission of grease-laden air."

* * * * *

UL, in performing its functions in accordance with its objectives, does not assume or undertake to discharge any responsibility of the manufacturer or any other party. UL shall not incur any obligation or liability for any loss, expense or damages, including incidental or consequential damages, arising out of or in connection with the use, interpretation of, or reliance upon this Guide Information.

Last Updated on 2013-05-16

The appearance of a company's name or product in this database does not in itself assure that products so identified have been manufactured under UL's Follow-Up Service. Only those products bearing the UL Mark should be considered to be Certified and covered under UL's Follow-Up Service. Always look for the Mark on the product.

UL permits the reproduction of the material contained in the Online Certification Directory subject to the following conditions: 1. The Guide Information, Assemblies, Constructions, Designs, Systems, and/or Certifications (files) must be presented in their entirety and in a non-misleading manner, without any manipulation of the data (or drawings). 2. The statement "Reprinted from the Online Certifications Directory with permission from UL" must appear adjacent to the extracted material. In addition, the reprinted material must include a copyright notice in the following format: "© 2018 UL LLC".

UL and the UL logo are trademarks of UL LLC ©2018 All Rights Reserved.
[About](#) [Privacy Policy](#) [Terms & Conditions](#) [Access Your Data](#)

Project No. 09NK02476_____



File E151487



Page 1

Total Number  pages in this package 9

TEST LOCATION:			
<input checked="" type="checkbox"/> 	or Affiliate	<input type="checkbox"/> WTDP	<input type="checkbox"/> CTDP
<input type="checkbox"/> OTHER			
Company Name UL-NBK			

CLIENT  INFORMATION	
Company Name	Turbochef Technologies Inc
Address	4240 International Pky Carrollton TX, 75007

AUDIT INFORMATION:			
<input checked="" type="checkbox"/> Description of Tests	Per Standard No.	UL710B	Edition 1st
<input checked="" type="checkbox"/> 	Tests Conducted by+	<u>Leo Carrillo/</u>	Signature
Witnessed at client facility		Printed name	Signature
Reviewed 	accepted by Respon 	<u>William G. Morler</u>	<u>William G. Morler</u>
		Printed Name	Signature

<input checked="" type="checkbox"/> TESTS TO BE CONDUCTED:				
Test 	Start	Done	Test Name	<input type="checkbox"/>  mments/Parameters <input checked="" type="checkbox"/>  ts Conducted by ++
1	<u>2009-02-10</u>	<u>2009-03-09</u>	<u>Capture Test (Grease-laden vapors)</u>	
2	<u>2009-03-03</u>	<u>2009-03-06</u>	<u>EPA202</u>	<u>++ Joe Garrett</u>
3	<u>2009-02-11</u>	<u>2009-02-11</u>	<u>Input Test</u>	

Test Equipment- See "TEST EQUIPMENT INFORMATION"
 Samples - See "TEST SAMPLE IDENTIFICATION"

Instructions -
 + - When all tests are conducted by one person, printed name and signature can be inserted here instead of including printed name and signature on each page containing data. Must indicate number of pages in the data package.
 ++ - When a test conducted by more than one person, printed name and signature of person conducting the test can be inserted next to the test name instead of including printed name and signature on each page containing data. Must indicate number of pages in the data package.

Special Instructions -

TEST EQUIPMENT INFORMATION

Inst. ID No.	Instrument	Test Number +, Test Title or Conditioning	Function	Last Date	Next Date

+ - If Test Number is used, the Test Number must be identified on the data sheet pages or on the Data Sheet Package cover page.

The following additional information is required when using client's or rented equipment, or when a UL ID Number for an instrument number is not used. The Inst. ID No. below corresponds to the Inst. ID No. above.

Inst. ID No.	Make/Model/Serial Number/Asset No.

The M&TE used for tests [**have**] [~~do not have~~] minimum required accuracy and range/functions, and [**were**] [~~were not~~] calibrated to assure these levels. (Per equipment group)

Test equipment information is recorded on UL's Laboratory Project Management (LPM)/Laboratory Equipment Management (LEM) database. (This statement may be selected only if datasheets are completed electronically at a UL facility)

TEST SAMPLE IDENTIFICATION:

The table below is provided to provide correlation of sample numbers to specific product related information. Refer to this table when a test identifies a test sample by "Sample No." only.

Sample Card No.	Date Received	<input type="checkbox"/> Test No.	Sample No.	Manufacturer, Product Identification and Ratings
185946	2-3-09	All	1	Turbochef, i3 Oven, rated 240V 42A

INPUT TEST:

METHOD

[X] The supply voltage was adjusted to voltage and frequency as noted in "General Test Considerations", 240 V, 60 Hz.

The power input was measured with the appliance at the intended operating temperature under full-load conditions.

RESULTS

Operating Conditions	V	A	W
Rated	240	42	10080
Unit energized (240V)	240	42.5	9474

TEST FOR EVOLUTION OF SMOKE OR GREASE-LADEN AIR:

The Model i3 oven with integral system to limit the emission of grease-laden vapors was tested using a method derived from EPA Method 202. The manufacturer also provided frozen pepperoni pizzas for the test.

A 8 in. by 6 in. rectangular, 108 in. tall sheet metal stack was constructed on top of a sheet metal hood and mounted above the exhaust vent of the oven. A sampling port was located approximately 80 in. downstream from the hood exhaust, at which point it was determined there was laminar flow. The sampler was assembled and an out of stack filter was used. A pre-leak check was conducted and determined to be > 0.02 ft/min. Sampling was determined to be done at 8 traverse points.

The oven with integral system was operated normally by cooking the following foods:

12 in. pepperoni pizza (Tombstone, with 19 pepperonis per pizza), each cooked for 3 minutes with 00 seconds between loads for 8 hours (total of 160 pizzas). Oven was set at the following duty:

Temp	Event #	% Time.	% Top	% Bottom	% Microwave Energy
500°F	1	<u>50</u>	<u>40</u>	<u>70</u>	<u>60</u>
	2	<u>50</u>	<u>70</u>	<u>50</u>	<u>70</u>
	3				
	4				
	5	-	-	-	-
	6	-	-	-	-
	7	-	-	-	-
	8	-	-	-	-

During the cooking operation, it was noted whether or not visible effluents evolved from the air exhaust of the hood. Gauge, meter and temperature readings were taken and recorded every 10 min. After cooking, the condition of the duct was noted and a post-leak check was conducted and determined to be < 0.02 ft³/min.

After being allowed to cool, the sampling equipment was disassembled; the filter was removed, and placed into a sample container labeled No. 1. The liquid in impingers Nos. 1, 2, and 3 were volumetrically measured and transferred to sample container No. 3. The silica gel and impinger No. 4 was transferred to sample container No. 5. The nozzle, probe and impingers were rinsed three times with water and the rinse was added to container No. 3. These parts were also rinsed three times with acetone and transferred to container No. 4. All additional inter surfaces of the sampling terrain glassware were rinsed with methylene chloride three times; the rinse was transferred to container No. 6. A blank of acetone approximately equivalent to the amount used for rinses was aliquoted into container No. 2, the same was done for the distilled de-ionized water and methylene chloride except that these were aliquoted into their own individual containers labeled No. 7 and 8 respectively. All containers were properly labeled and sealed, then the liquid levels in all the containers were marked.

The analysis phase was done in accordance with EPA Method 202, using the out of stack filter.

RESULTS

There [~~was~~][**was no**] visible smoke was emitted from the exhaust of the hood during the normal cooking operation. There [~~was~~][**was no**] noticeable amounts of smoke accumulated in the test room after 8 hours of continuous cooking.

The total amount of grease-laden effluents collected by the sampling equipment was found to be 0.32 mg/m³, which is less than 5 mg/m³ in each case.

CONDENSIBLE MATTER (PIZZA)
Lab Analysis

Sample Bottle No.	Description	Start Volume, ml	Final Wt, mg
1	Filter Paper	N/A	649
2	Acetone Blank	92	0
3	Acetone Wash	80	0
4	Impinger Contents/wash	500 +60 = 560	3.0
5	MeCl ₂ Wash	92	0
6	Water Blank	500 + 65 = 565	0
7	MeCl ₂ Blank	112	0
8	Silica	N/A	N/A

Filter paper weight before test- 649_mg

|

Graduated cylinder # 9742 used for measurement. Certificate of analysis available on file in DWTU (water) lab jeg 3-3-09

Initial Weights (grams)

- 1) - 47.1392 - acetone blank
- 2) 50.9520 - acetone wash
- 3) 48.9557 - 4 & 5 MECL
- 4) 50.6657 - 6 & 7 MECL
- 5) 52.9628 - 4&5 water
- 6) 50.3086 - 4&5 water
- 7) 54.7795 - 4&5 water
- 8) 52.4101 - 4&5 water
- 9) 54.6273 - 4&5 water
- 10) 52.4944 -6&7 water
- 11) - 50.3810 -6&7 water
- 12) - 48.4919 -6&7 water
- 13) - 53.5413 -6&7 water
- 14) - 52.4960 -6&7 water

Final Weights (grams)

- 1) 47.1392 acetone blank
- 2) -50.9520 acetone wash
- 3) -48.9557 4 & 5 MECL
- 4) -50.6657 6 & 7 MECL
- 5) -52.9655 4&5 water
- 6) -50.3086 4&5 water
- 7) -54.7795 4&5 water
- 8) -52.4101 4&5 water
- 9) -54.6277 4&5 water
- 10) -52.4944 6&7 water
- 11) -50.3810 6&7 water
- 12) -48.4919 6&7 water
- 13) -53.5413 6&7 water
- 14) -52.4960 6&7 water

|
|

Analysis

- 1 The liquid level of all the sample bottles is to be measured.
- 2 The filter from sample bottle number one is to be removed and dried to constant weight by means of a desiccator or an oven. The weight of the filter is to be recorded.
- 3 The volume of sample bottle number two is to be determined. The liquid is then to be transferred to a beaker and evaporated to dryness. The volume of the liquid and the final weight of the condensable matter are to be recorded.
- 4 The volume of sample bottle number three is to be determined. The liquid is then to be transferred to a beaker and evaporated to dryness. The volume of the liquid and the final weight of the condensable matter are to be recorded.
- 5 The volumes of sample bottles number four and five are to be measured.
- 6 Sample bottles number four and five are to be combined. The organic phase is to be mixed, separated, and then repeated with two MeCl₂ washes.
- 7 The organic extracts obtained from the procedure in 6 are to be placed in a beaker and evaporated to a constant weight. The final weight is to be recorded.
- 8 The inorganic phase is to be placed in a beaker and evaporated to dryness. The final weight is to be recorded.
- 9 The volumes of sample bottles number six and seven are to be determined. Sample bottles six and seven are to be analyzed according to 8 and 7 respectively.

END OF DATASHEET PACKAGE. THIS PAGE INTENTIONALLY LEFT BLANK

UL® (KNLZ) Emissions by Product

Ventless Requirement: <5.00 mg/m³

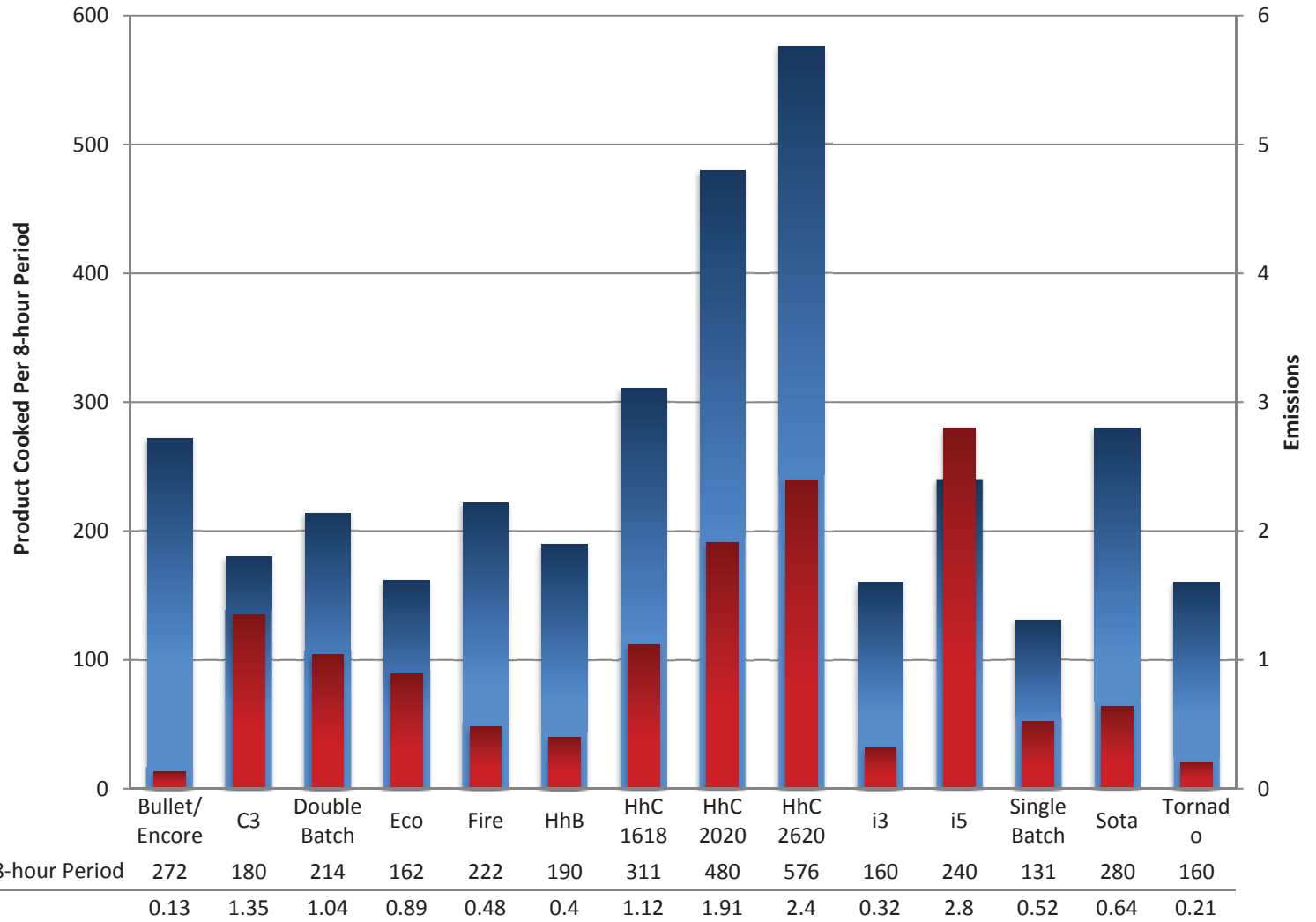



October 18, 2004

Mr. Mike Denny
 Building Services,
 224 West Knight St.
 City of Sioux Falls,
 South Dakota, 57102
 Ph: 605-367-8252

Re: Fire and smoke containment

Dear Mr. Denny:

The TurboChef ovens have been extensively tested and conform to UL 923 and UL KNLZ standards. The UL 923 standard is the electrical/product safety standard and the KNLZ is the low particulate matter emissions standard to which we conform. While both standards address different aspects of the oven, they both have inherent overlap as it relates to grease/smoke/fire handling.

As it relates specifically to fire safety, UL 923 specifies:

Section 57 Cavity Fire Containment Test:

The performance of an appliance subjected to this test shall be considered acceptable if all of the following conditions are met:

- a) There is no emission of fire, flame, or molten metal outside the appliance nor glowing or ignition of the cheesecloth, tissue paper, or wood surface;*
- b) The fuse rated 3 A does not open;*
- c) Following the test, the appliance complies with the requirements of Leakage Current, Section 33, and Dielectric Voltage-Withstand Test, Section 39, as applicable to primary circuits; and*
- d) Following the test and following 10 c of operation (opening and closing the door), the appliance complies with the requirements in 57.12. The radiation emission shall not exceed 5mW/cm².*

Test Method:

Section 57.2 requires that 4 potatoes each weighing between 150g and 200g be placed inside the oven under test and cooked using full microwave power and hot air (if applicable) until the potatoes catch fire. Note: The test must be repeated until it catches fire. During this test, pieces of tissue paper and cheesecloth are placed above, below and around the product to ensure that the fire and/or excessive heat generated is safely contained within the confines of the appliance.

As it relates to grease handling, UL KNLZ specifies:

UL KNLZ Guide Information Excerpt:

"These appliances have been evaluated for the limit of 5 mg/m³ for the emission of grease-laden air to the room ambient in accordance with the recommendations of the National Fire Protection Association Standard for Ventilation Control and Fire Protection of Commercial Cooking Operations, NFPA 96, using the EPA-202 test method prescribed for cooking appliances provided with integral recirculating air systems."

Test Method:

The UL KNLZ category requires that products must have less than 5.0 mg/m³ of particulate matter emissions during 8 continuous hours of cooking a "worst case" food product as measured by EPA 202. Note: Our products were tested using full-fat pepperoni pizzas.

As it pertains specifically to smoke: Smoke typically consists of visible grease particulate that escapes from a product during operation. Our ovens utilize a recirculating airpath that is catalytic scrubbed, thus the airborne grease is combusted as it crosses our catalyst. Given this, under typical/normal operating conditions, our product does not emit smoke.

If you have any issues or specific questions regarding the above, please contact me directly.

Best regards,

James K. Pool III

James K. Pool III
Vice President Engineering,
TurboChef Technologies, Inc.,
Ph: 214.379.6020
Email: james.pool@turbochef.com

TurboChef Energy Calculator

User Inputs

Total Operation Time per Day (hours)	12	hours
Cook Cycle Time (seconds)	180	seconds
Number of Cooks per Day	100	total
Energy Cost/kWhr (\$)	0.11	\$/kWhr

Constants		i3
Power Warm-up (watts)		3,880
Power Cooking (watts)		5,600
Power Idle (watts)		1,587
Time Warm-up (seconds)		900

Energy = (Power x time), where power is in watts and time is in seconds

$E_{total} = E_{idle} + E_{cooking} + E_{warmup}$

Ave Power = $E_{total} / \text{total time per day}$

Calculated Times		i3
Time (cooking, sec)		18,000
Time (idle, sec)		24,300
Time Check		12
Eidle (kJ)		38,564
Ewarm-up (kJ)		3,492
Ecooking (kJ)		100,800
Etotal (kJ)		142,856
Etotal (kWhr)		39.68
Avg Power/Day (kW)		3.31
Tons of Cooling		0.94
Cost/Day (\$)		\$4.37
Cost/Month (\$)		\$131.10
Cost/Year (\$)		\$1,595.05



i3 Oven Surface Temperatures

This document illustrates the surface temperature testing data reported for the TurboChef model i3 oven. Measurements were recorded after four hours of idle and after two hours of subsequent cooking. The oven temperature was set to 520°F (271°C) for the duration of the test.

After 4-Hour Idle at 520°F/271°C (Values in °F/°C)

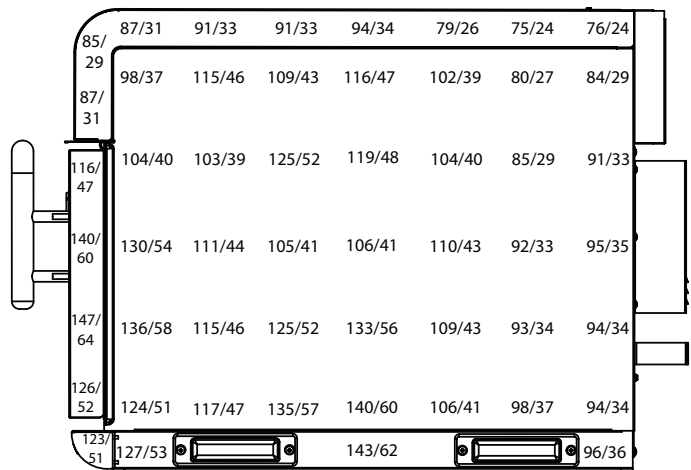
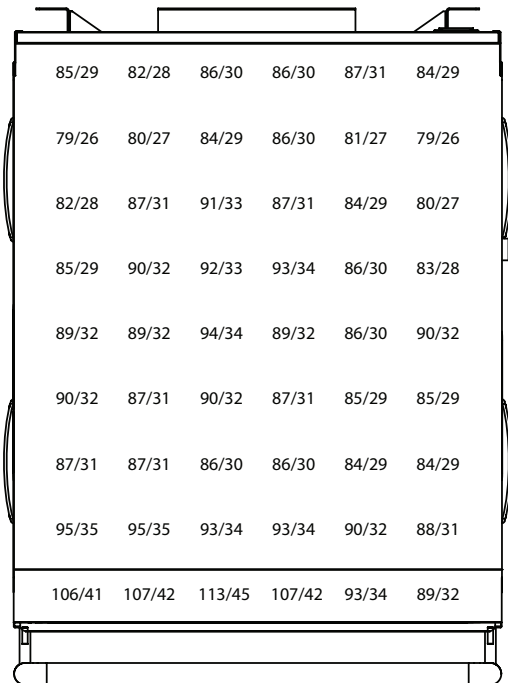
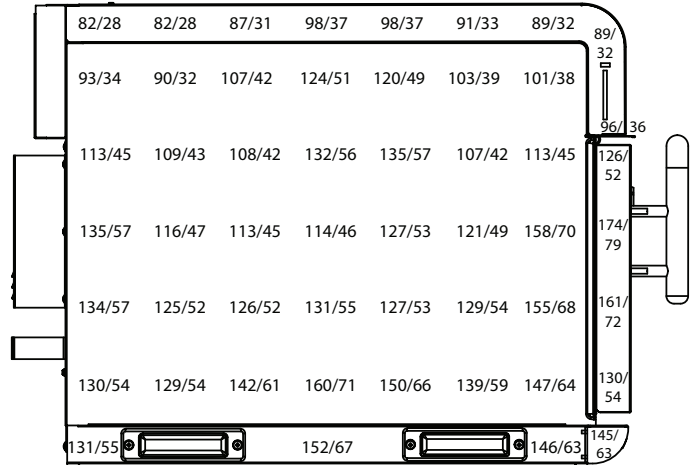
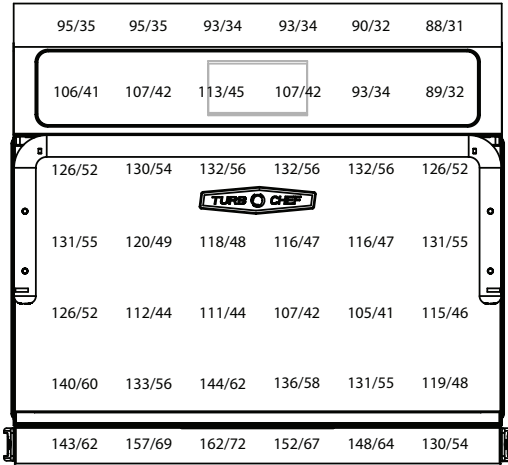

After 4-Hour Idle and 2 Hours of Cooking at 520°F/271°C (Values in °F/°C)

86/30	86/30	86/30	88/31	86/30	82/28
87/31	91/33	97/36	100/38	90/32	80/27
102/39	115/46	120/49	119/48	110/43	102/39
110/43	97/36	96/36	94/34	90/32	105/41
107/42	97/36	98/37	98/37	96/36	99/37
128/53	130/54	134/57	127/53	114/46	106/41
124/51	122/50	128/53	126/52	120/49	109/43

78/26	78/26	78/26	79/26	79/26	79/26	79/26	80/27
83/28	81/27	82/28	82/28	83/28	83/28	83/28	85/29
92/33	89/32	87/31	87/31	86/30	87/31	94/34	95/35
109/43	96/36	95/35	91/33	91/33	97/36	124/51	127/53
112/44	100/38	101/38	96/36	95/35	103/39	128/53	136/58
110/43	105/41	114/46	128/53	120/49	113/45	124/51	125/52
109/43			127/53			120/49	122/50

80/27	80/27	78/26	78/26	80/27	80/27
77/25	77/25	77/25	75/24	76/24	80/27
79/26	80/27	80/27	78/26	78/26	79/26
80/27	80/27	81/27	79/26	78/26	78/26
80/27	82/28	82/28	80/27	78/26	78/26
80/27	81/27	80/27	79/26	79/26	81/27
81/27	82/28	82/28	81/27	80/27	80/27
86/30	86/30	86/30	88/31	86/30	82/28
87/31	91/33	97/36	100/38	90/32	80/27

74/23	75/24	72/22	72/22	70/21	71/22	72/22
83/28	83/28	80/27	79/26	79/26	79/26	79/26
89/32	90/32	83/28	82/28	85/29	81/27	85/29
106/41	91/33	85/29	89/32	104/40	86/30	93/34
115/46	95/35	110/43	120/49	100/38	88/31	91/33
108/42	100/38	114/46	127/53	102/39	92/33	90/32
99/37			112/44			83/28



CYNTHIA A. HARDING, M.P.H.
Interim Director

JEFFREY D. GUNZENHAUSER, M.D., M.P.H.
Interim Health Officer

ANGELO J. BELLOMO, REHS, QEP
Deputy Director for Health Protection

TERRI S. WILLIAMS, REHS
Director of Environmental Health

5050 Commerce Drive
Baldwin Park, California 91706
TEL (626) 430-5374 • FAX (626) 813-3000

www.publichealth.lacounty.gov

BOARD OF SUPERVISORS

Hilda L. Solis
First District

Mark Ridley-Thomas
Second District

Sheila Kuehl
Third District

Don Knabe
Fourth District

Michael D. Antonovich
Fifth District

September 8th, 2016

James K. Pool III
Senior Vice President, Engineering
TurboChef Technologies, Inc.
4240 International Parkway, Suite 101
Carrollton, Texas 75007

Ventilation Exemption Plan Check No.	ME-2011-001
Application Type:	Equipment specific 208 / 240 V; 9000W
Effective Date:	8/1/2016
Expiration Date:	8/1/2021
Telephone:	(214) 379-6020
Email:	James.Pool@turbochef.com

RE: Exemption from mechanical exhaust ventilation for TurboChef Technologies, Inc. Model i3

Dear Mr. Pool:

The County of Los Angeles Department of Public Health, Environmental Health, Plan Check has completed a review of the TurboChef Technologies, Inc. Model: i3 oven for exemption from the mechanical exhaust ventilation requirements of Section 114149.1(a) of the California Retail Food Code.

You have provided documentation that these ovens have Underwriter's Laboratory KNLZ approval, and also provided the results of the eight-hour cooking emissions test conducted on the Tornado (NGC) oven. The test results indicate that the particulate matter concentration produced was 0.32 mg/m³, which is below the limit of 5 mg/m³ to be considered a low grease emission appliance.

TurboChef Oven
August 1, 2016

Therefore, additional mechanical ventilation in the form of a Type I and Type II hood is not required by the County of Los Angeles Department of Public Health, provided the following contingencies are met:

1. There shall be no more than two unventilated model i3 oven per food facility.
2. No other heat producing food related equipment ventilation shall be permitted in a food facility without the addition of mechanical ventilation.
3. The equipment must be installed, serviced, and maintained according to the manufacture's specifications.
4. Any modification, alteration, or removal of equipment, including any component of the integral air filtration systems voids both the ANSI certification of the equipment and this limited exemption. All air filtration components must be installed and operational at all times the appliance is in use.
5. The i3 oven shall be used for cooking or warming of pizza, bread, bakery products, or similar items only. No raw animal protein products shall be cooked in the equipment unless mechanical ventilation is provided.
6. Pre-cooked foods such as animal, fish or skinless poultry protein products may be reheated in the i3 oven.
7. The i3 oven must be operated in a well-ventilated area approved for food preparation.
8. If the ownership changes at a food facility that is operating the exempt equipment, then the new owner/ operator will be informed of the operating conditions.
9. This exemption from mechanical exhaust ventilation shall not be deemed to supersede any local building and fire code requirements pertaining to electrical and fire safety.

TurboChef Oven
August 1, 2016

This exemption shall be in effect for a period of five years from the date of this letter, or until revoked. However, exemption shall not preclude this Department from requiring the installation of mechanical exhaust ventilation when operation of the i3 oven at a specific location results in a sanitation or safety violation. These problems may include, but are not limited to, problems of installation, use, maintenance, cleaning or other site specific considerations which exceed the above limitations or pose a discernable health or safety hazard.

This letter may be used as evidence of the evaluation of the TurboChef Model i3 rapid cooking ovens. However, it is not to be construed as an endorsement of the subject items and may not be used for advertising or promotional purposes.

Should you have any questions or need additional information, please contact me at (626) 430-5560.

Sincerely



Denise Noborio, R.E.H.S.
Chief EHS
Plan Check Program



Marco Espinoza, R.E.H.S.
Environmental Health Specialist IV
Plan Check Program



TURBOCHEF TECHNOLOGIES, INC.

Installation Recommendations

TurboChef ventless ovens have internal systems for destroying grease laden vapor prior to the grease escaping the oven; therefore, the ovens are certified as non-grease emitting appliances. When following our recommendations, TurboChef ovens can be installed without the aid of a Type I or Type II hood per International Mechanical Code (2006, 2009, and 2012), NFPA 96, NFPA 101 (Life Safety Code), EPA 202, and Underwriter's Laboratory (UL KNLZ).

The following guide is intended to give relevant information for the ventless installation, operation, and maintenance of TurboChef ovens. It is important that these guidelines are followed and that the oven and surrounding areas be maintained regularly for optimal performance.

Certifications

Safety – cULus, TUV (CE)

Sanitation – NSF*, UL EPH*

Ventless – UL (KNLZ)



Electrical Requirements

TurboChef ovens must be installed on a circuit equal to the ratings listed below, per NEC sec 210.23, permissible loads.

Oven	Voltage	Current	Phase
Bullet	208/240 VAC	30 amp	1 Ph
C3	208/240 VAC	50 amp	1 Ph
Double Batch	208/240 VAC	50 amp	1 Ph
	208/240 VAC	30 amp	3 Ph
Eco			
Encore/Encore 2	208/240 VAC	30 amp	1 Ph
Fire	208/240 VAC	30 amp	1 Ph
HhB 2	208/240 VAC	30 amp	1 Ph
HhC 1618	208/240 VAC	30 amp	3 Ph
	208/240 VAC	50 amp	1 Ph
HhC 2020	208/240 VAC	50 amp	3 Ph
HhC 2620	208/240 VAC	50 amp	3 Ph
i1 (Panini, Söta, Waterless Steamer)	208/240 VAC	30 amp	1 Ph
i1 Söta Single Mag	208/240 VAC	20 amp	1 Ph
i3	208/240 VAC	40 amp	1 Ph
	208/240 VAC	30 amp	3 Ph
i5	208/240 VAC	50 amp	1 Ph
	208/240 VAC	30 amp	3 Ph
Single Batch	208/240 VAC	30 amp	1 Ph
Tornado	208/240 VAC	30 amp	1 Ph

* NSF certification applies to the Tornado, C3, and HhB 2 ovens only. UL EPH certification applies to all ovens except the C3.

Menu Requirements

TurboChef ovens have been approved by Underwriter's Laboratory for ventless operation (UL KNLZ listing) for all food items EXCEPT for foods classified as "fatty raw proteins." Such foods include bone-in, skin-on chicken, raw hamburger meat, raw bacon, raw sausage, steaks, etc.

The TurboChef certification includes precooked food items such as pizza toppings, sandwich meats, frozen appetizers, and cheeses. Additionally, raw, lean meats such as boneless, skinless chicken breasts and fish fall within the certification.

Cleaning Requirements

To ensure continued compliance with all health, building, and fire codes, users are required to:

- Use only TurboChef-approved cleaning chemicals.
- Follow monthly and quarterly cleaning instructions provided in the manual. Post cleaning instructions near the oven.
- Ventless installation requires that the areas around the oven (walls, ceilings, kitchen equipment, etc.) be cleaned as needed but no less than once every other month.

Installation Near Open Heat Source

When placing a TurboChef oven near an open heat source (see illustration below), strictly adhere to the following:

- If the oven is being placed near a grill or stove, a divider must exist between the oven and the open heat source, with a minimum of 6" (152 mm) between the oven and the divider.
- If the oven is being placed near a fryer, a divider must exist between the oven and fryer, with a minimum of 12" (305 mm) between the oven and the divider.
- The height of the divider must be greater than or equal to the height of the oven.

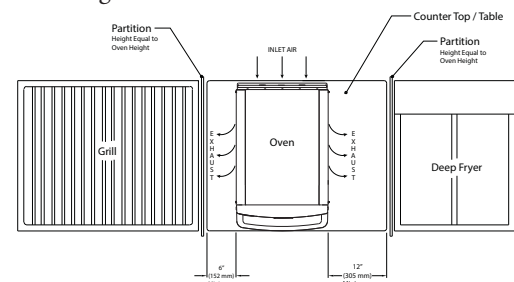



Oven Clearances

Verify the oven location has the following clearances on the top and each side. TurboChef ovens have built-in back bumpers that allow for the necessary spacing from the oven to the back wall.

Oven	Top	Sides
Bullet	5" (127 mm)	2" (51 mm)
C3	4" (102 mm)	2" (51 mm)
Double Batch	2" (51 mm)	2" (51 mm)
Eco	5" (127 mm)	1" (25 mm)
Encore/Encore 2	5" (127 mm)	2" (51 mm)
Fire	2" (51 mm)	2" (51 mm)
HhB 2	2" (51 mm)	2" (51 mm)
HhC 1618	10" (254 mm)	0" (0 mm)
HhC 2020	10" (254 mm)	0" (0 mm)
HhC 2620	10" (254 mm)	0" (0 mm)
i1 (Panini, Söta / Söta Single Mag, Waterless Steamer)	5" (127 mm)	1" (25 mm)
i3	19" (483 mm)	2" (51 mm)
i5	19" (483 mm)	2" (51 mm)
Single Batch	2" (51 mm)	2" (51 mm)
Tornado	4" (102 mm)	2" (51 mm)

Ventilation

TurboChef ovens must be installed in a well-ventilated space. The space should have an exhaust rate of .70 cfm per square foot of kitchen space and an additional 100 sq. ft. (9.3 m²) of virtual space per ventless cooking appliance (TurboChef or any other).

If the air inlet is for general exhaust, pursuant to requirements for 507.2.2, paragraph 2, locate the air inlet above the center point of each oven.

The heat load from TurboChef ovens is mostly sensible. The only latent heat present is due to evaporation during the cooking process. When installing a TurboChef oven, the space must have the following tons of AC per oven installed.

Oven	Tons of AC
Bullet	0.5
C3	0.63
Double Batch	1.15
Eco	0.89
Encore/Encore 2	0.45
Fire	0.55
HhB 2	0.84
HhC 1618	1.00
HhC 2020	1.47
HhC 2620	1.82
i1 (Panini, Söta/ Söta Single Mag, Waterless Steamer)	0.3
i3	0.9
i5	1.3
Single Batch	0.75
Tornado	0.58

How the Ovens are Tested

TurboChef ovens are evaluated according to UL. The evaluation entails placing the test oven in an environmental chamber built to capture all emissions escaping during idle, cooking, and door-open conditions. During the eight-hour test period, a typical worst-case food item is cooked continuously, and 100% of condensable and non-condensable emissions from the product are collected and analyzed according to the EPA 202 Test Method. At the conclusion of the test, the total concentration of particulate matter (emissions) must be less than 5.0 mg/m³ for the oven to be certified for ventless operation. Cooking devices that measure above the 5.0 mg/m³ threshold are considered to produce grease and must be installed under Type I ventilation, according to International Mechanical Code.

TurboChef ovens are well below the 5.0 mg/m³ threshold as shown below.

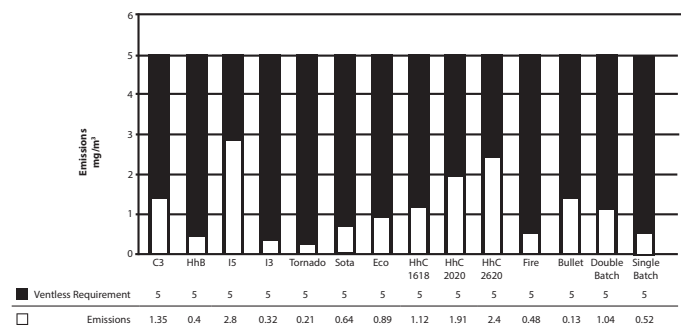

Contact Information

For questions regarding a ventless installation, email ventless.help@turbochef.com. For questions or concerns regarding an existing installation, contact Customer Service at 1.800.908.8726, Option 1.