

PLEXOR



Features & Benefits

- Three (3) cooking technologies in one (1) appliance: rapid cook, impingement, convection, or any combination
- Operated by a single plug
- Single user interface makes training and operation simple
- Autoload/unload
- Ventless – integral recirculating catalytic converter for UL® (KNLZ) listed ventless operation
- Adaptive power management ensuring consistent results while power sharing
- Modular design: mix and match to fit your menu – change configuration with module field swaps
- Available in left-to-right, right-to-left, and front-to-back configurations
- Open Kitchen™ ready
- 7-inch capacitive touch screen with tempered glass cover (CON-7168)
- Smart menu system capable of storing unlimited recipes
- Comes standard with cart and sealing gasket
- Includes plug and cord (6 ft. nominal)

Connectivity Part Numbers

- MDD-1001 - Initial Equipment
- MDD-1002 - Additional Equipment
- MDD-1005 - Additional Year (PhD SAAS)



Shown above with the convection, rapid cook, impingement modules installed. See page two for more information.

VENTILATION

- UL (KNLZ) listed for ventless operation.†
- EPA 202 test (8 hr):
 - Product: Pepperoni Pizzas
 - Convection Results: 0.20 mg/m³
 - Impingement Results: 1.33 mg/m³
 - Rapid Cook Results: 1.05 mg/m³
 - Ventless Requirement: <5.00 mg/m³
- Internal catalytic filtration to limit smoke, grease, and odor emissions.



SPECIFICATIONS

PHASE
3 Phase

VOLTAGE
208/240V

CURRENT
39A-49A

MAX CIRCUIT
50A

PLUG
NEMA 15-50P



This product conforms to the ventilation recommendations set forth by NFPA96 using EPA202 test method.

* Smart Voltage Sensor Technology does not compensate for lack of or over voltage situations. It is the responsibility of the owner to supply voltage to the unit according to the specifications on the back of this sheet.

† Ventless certification is for all food items except for foods classified as "fatty raw proteins." Such foods include bone-in, skin-on chicken, raw hamburger meat, raw bacon, raw sausage, steaks, etc. If cooking these types of foods, consult local HVAC codes and authorities to ensure compliance with ventilation requirements.

If you have questions regarding ventless certifications or local codes, please email ventless.help@turbochef.com TurboChef reserves the right to make substitutions of components or change specifications without prior notice.

©2021 TurboChef Technologies, LLC
DOC-1818 / Rev J / February 2023

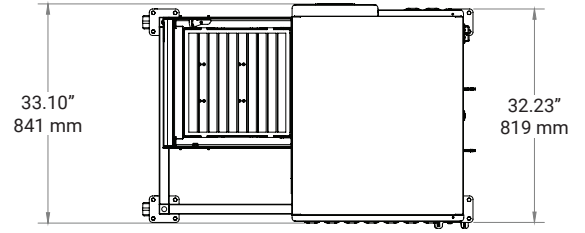
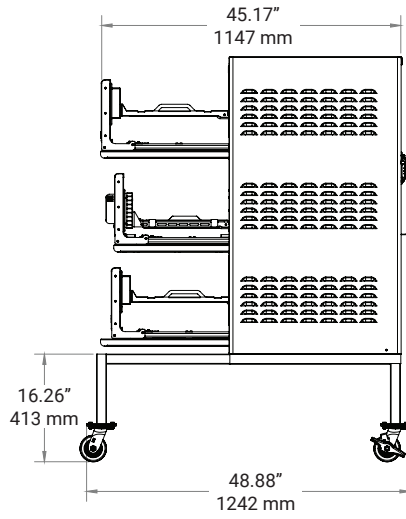
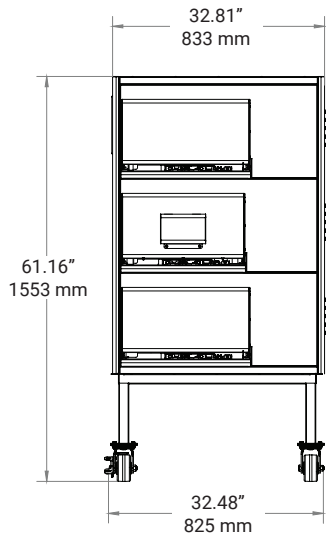

LEFT TO RIGHT/RIGHT TO LEFT

Height	61.16"	1553 mm
Width	48.88"	1242 mm
Depth	32.81"	833 mm

OVEN ONLY

Height	44.90"	1140 mm
Width	45.17"	1147 mm
Depth	33.10"	841 mm
Weight	610 lb.	277 kg

WALL CLEARANCE

Top	2"	51 mm
Sides	2"	51 mm

SHIPPING

Freight Class	175
Cube	48"x72"x58"
Shipping Weight	670 lb. (304 kg)
F.O.B.	Carrollton, TX

IMPINGEMENT – COOK CHAMBER

Height	3.4"	86 mm
Width	16.5"	419 mm
Depth	16.3"	414 mm
Volume	0.53 cu.ft.	15.0 liters

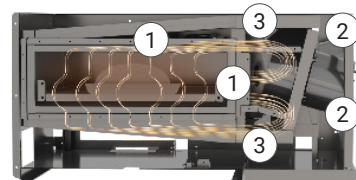

1. Heating Elements
2. Blower Motors
3. Catalytic Converters

RAPID COOK – COOK CHAMBER

Height	4.2"	107 mm
Width	14.0"	356 mm
Depth	14.0"	356 mm
Volume	0.48 cu.ft.	13.6 liters

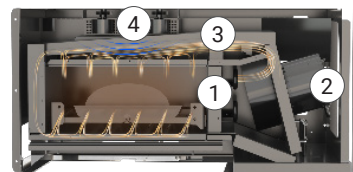

1. Heating Elements
2. Blower Motor
3. Catalytic Converter
4. Top-launched Microwave

CONVECTION – COOK CHAMBER

Height	3.7"	94 mm
Width	16.5"	419 mm
Depth	16.3"	414 mm
Volume	0.57 cu.ft.	16.1 liters

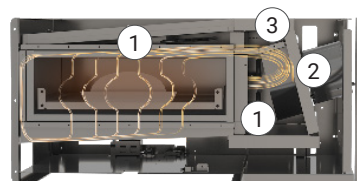

1. Heating Elements
2. Blower Motors
3. Catalytic Converters